

 APOLLO DISPLAY
TECHNOLOGIES



 DISTEC



 DISPLAY
TECHNOLOGY



Datasheet

KOE

TX16D201VM0BAB

KO-01-006

KOE

JDI Group

Kaohsiung Opto-Electronics Inc.

FOR MESSRS : _____

DATE : Mar. 13th, 2020

CUSTOMER'S ACCEPTANCE SPECIFICATIONS

TX16D201VM0BAB

Contents

No.	ITEM	SHEET No.	PAGE
1	COVER	7B64PS 2701-TX16D201VM0BAB-3	1-1/1
2	RECORD OF REVISION	7B64PS 2702-TX16D201VM0BAB-3	2-1/1
3	GENERAL DATA	7B64PS 2703-TX16D201VM0BAB-3	3-1/1
4	ABSOLUTE MAXIMUM RATINGS	7B64PS 2704-TX16D201VM0BAB-3	4-1/1
5	ELECTRICAL CHARACTERISTICS	7B64PS 2705-TX16D201VM0BAB-3	5-1/2~2/2
6	OPTICAL CHARACTERISTICS	7B64PS 2706-TX16D201VM0BAB-3	6-1/2~2/2
7	BLOCK DIAGRAM	7B64PS 2707-TX16D201VM0BAB-3	7-1/1
8	RELIABILITY TESTS	7B64PS 2708-TX16D201VM0BAB-3	8-1/1
9	LCD INTERFACE	7B64PS 2709-TX16D201VM0BAB-3	9-1/7~7/7
10	OUTLINE DIMENSIONS	7B64PS 2710-TX16D201VM0BAB-3	10-1/2~2/2
11	APPEARANCE STANDARD	7B64PS 2711-TX16D201VM0BAB-3	11-1/3~3/3
12	PRECAUTIONS	7B64PS 2712-TX16D201VM0BAB-3	12-1/2~2/2
13	DESIGNATION OF LOT MARK	7B64PS 2713-TX16D201VM0BAB-3	13-1/1

ACCEPTED BY: _____

PROPOSED BY: Oblack Tsai

2. RECORD OF REVISION

DATE	SHEET No.	SUMMARY
Oct.03,'19	7B64PS 2710 – TX16D201VM0BAB-2 Page 10-1/2	10. OUTLINE DIMENSIONS Added : the dimensions of mounting hole
Mar.13,'20	7B64PS 2703 – TX16D201VM0BAB-3 Page 3-1/1	3. GENERAL DATA Revised : Pixel Pitch : 0.126(W) mm x 0.126 (H) mm ↓ Pixel Pitch : 0.12675(W) mm x 0.12675 (H) mm

3. GENERAL DATA

3.1 DISPLAY FEATURES

This module is a 6.4" XGA of 4:3 format LTPS TFT. The pixel format is vertical stripe and sub pixels are arranged as R (red), G (green), B (blue) sequentially. This display is RoHS compliant, COG (chip on glass) technology and LED backlight are applied on this display that made in Taiwan.

Part Name	TX16D201VM0BAB
Module Dimensions	153.0(W) mm x 118.0(H) mm x 8.7 (D) mm typ.
LCD Active Area	129.792(W) mm x 97.344(H) mm
Pixel Pitch	0.12675(W) mm x 0.12675 (H) mm
Resolution	1024 x 3(RGB)(W) x 768(H) dots
Color Pixel Arrangement	R, G, B Vertical stripe
LCD Type	LTPS TFT; Transmissive Normally Black
Top Polarizer Type	Glare Polarizer Film
Display Type	Active Matrix
Number of Colors	16.7M Colors (8-bit RGB)
Backlight	Light Emitting Diode(LED)
Weight	190g typ.
Interface	LVDS; 20 pins
Power Supply Voltage	3.3V for LCD; 12V for Backlight
Power Consumption	0.231 W for LCD; 4.56 W for Backlight
Viewing Direction	Super Wide Version (In-Plane Switching)

4. ABSOLUTE MAXIMUM RATINGS

4.1 ENVIRONMENTAL ABSOLUTE MAXIMUM RATINGS

Item	Symbol	Min.	Max.	Unit	Remarks
Supply Voltage	V _{DD}	-0.3	4.5	V	-
Input Voltage of Logic	V _I	-0.3	V _{DD}	V	Note 1
Operating Temperature	T _{op}	-30	80	°C	Note 2
Storage Temperature	T _{st}	-30	80	°C	Note 2
Backlight Input Voltage	V _L	0	15	V	-

Note 1: The rating is defined for the signal voltages of the interface such as CLK and pixel data pairs.

Note 2: The maximum rating is defined as above based on the panel surface temperature, which might be different from ambient temperature after assembling the panel into the application. Moreover, some temperature-related phenomenon as below needed to be noticed:

- Background color, contrast and response time would be different in temperatures other than 25°C.
- Operating under high temperature will shorten LED lifetime.

5. ELECTRICAL CHARACTERISTICS

5.1 LCD CHARACTERISTICS

$T_a = 25\text{ }^\circ\text{C}$, $V_{SS} = 0\text{V}$

Item	Symbol	Condition	Min.	Typ.	Max.	Unit	Remarks
Power Supply Voltage	V_{DD}	-	3.0	3.3	3.6	V	-
Differential Input Voltage for LVDS Receiver Threshold	V_I	"H" level	$0.7V_{DD}$	-	V_{DD}	mV	Note 1
		"L" level	V_{SS}	-	$0.3V_{DD}$		
Power Supply Current	I_{DD}	$V_{DD}=3.3\text{V}$	-	70	90	mA	Note 2
Frame Frequency	f_{Frame}	-	55	60	65	Hz	-
CLK Frequency	f_{CLK}	-	51	56.3	66	MHz	-
Input Voltage of Logic	V_I	"H" level	2.1	-	3.6	V	-
		"L" level	0	-	0.5		

Note 1: VCM 1.2V is common mode voltage of LVDS transmitter and receiver. The input terminal of LVDS transmitter is terminated with 100Ω .

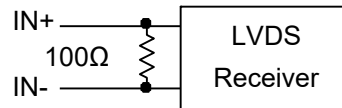

Note 2: An all white check pattern is used when measuring I_{DD} . f_{Frame} is set to 60 Hz. Moreover, 0.5A fuse is applied in the module for I_{DD} . For display activation and protection purpose, power supply is recommended larger than 1.25A to start the display and break fuse once any short circuit occurred.

5.2 BACKLIGHT CHARACTERISTICS

$T_a = 25^\circ\text{C}$

Item	Symbol	Condition	Min.	Typ.	Max.	Unit	Remarks
LED Input Voltage	V_L	-	10.8	12.0	13.2	V	Note1
LED Forward Current (Dim Control)	I_L	0% duty	350	380	420	mA	Note 2
		100% duty	-	10	-		
LED lifetime	-	$I_{LED} = 380\text{ mA}$	-	70K	-	hrs	Note 3

Note 1: As Fig. 5.1 shown, LED current is constant, 380 mA, controlled by the LED driver when applying 12V.

Note 2: Dimming function can be obtained by applying PWM signal from the display interface DIM (No.6pin) of CN2. The recommended PWM signal is 200Hz ~ 1K Hz with 3.3V amplitude.

Note 3: The estimated lifetime is specified as the time to reduce 50% brightness by applying 380 mA at 25°C .

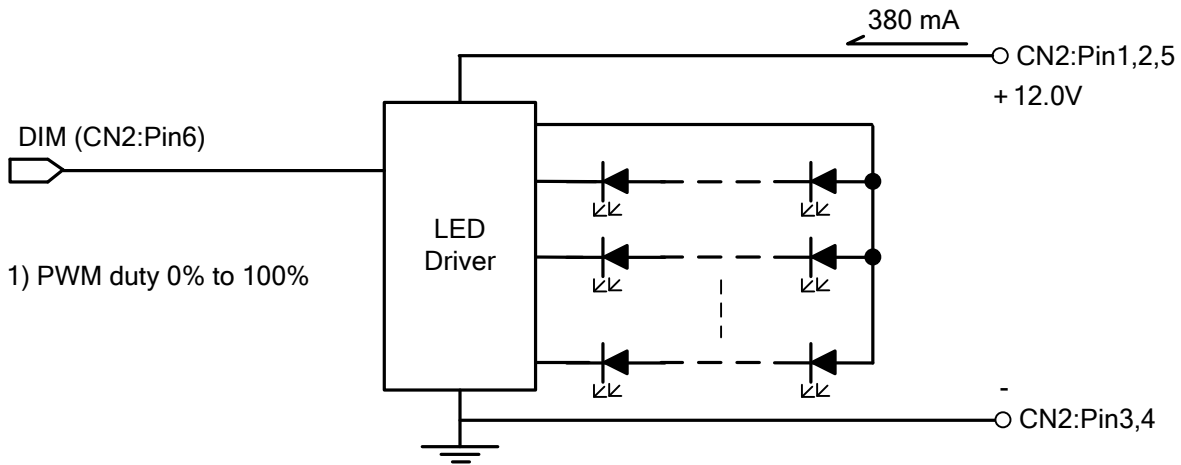

Fig. 5.1

6. OPTICAL CHARACTERISTICS

The optical characteristics are measured based on the conditions as below:

- Supplying the signals and voltages defined in the section of electrical characteristics.
- The backlight unit needs to be turned on for 30 minutes.
- The ambient temperature is 25 °C.
- In the dark room less than 100lx, the equipment has been set for the measurements as shown in Fig 6.1.

$$T_a = 25\text{ }^\circ\text{C}, f_{\text{Frame}} = 60\text{ Hz}, V_{\text{DD}} = 3.3\text{ V}$$

Item	Symbol	Condition	Min.	Typ.	Max.	Unit	Remarks	
Brightness of White	-	$\phi = 0^\circ, \theta = 0^\circ,$ $I_{\text{LED}} = 380\text{ mA}$	1100	1400	-	cd/m ²	Note 1	
Brightness Uniformity	-		75	-	-	%	Note 2	
Contrast Ratio	CR		400	800	-	-	Note 4	
Response Time	$T_r + T_f$	$\phi = 0^\circ, \theta = 0^\circ$	-	30	-	ms	Note 5	
NTSC Ratio	-	$\phi = 0^\circ, \theta = 0^\circ$	-	60	-	%	-	
Viewing Angle	θ_x	$\phi = 0^\circ, \text{CR} \geq 10$	70	85	-	Degree	Note 6	
	$\theta_{x'}$	$\phi = 180^\circ, \text{CR} \geq 10$	70	85	-			
	θ_y	$\phi = 90^\circ, \text{CR} \geq 10$	70	85	-			
	$\theta_{y'}$	$\phi = 270^\circ, \text{CR} \geq 10$	70	85	-			
Color Chromaticity	Red	X	$\phi = 0^\circ, \theta = 0^\circ$	0.57	0.62	0.67	-	Note 7
		Y		0.28	0.33	0.38		
	Green	X		0.27	0.32	0.37		
		Y		0.53	0.58	0.63		
	Blue	X		0.11	0.16	0.21		
		Y		0.03	0.08	0.13		
	White	X		0.26	0.31	0.36		
		Y		0.28	0.33	0.38		

Note 1: The brightness is measured from the panel center point, P5 in Fig. 6.2, for the typical value.

Note 2: The brightness uniformity is calculated by the equation as below:

$$\text{Brightness uniformity} = \frac{\text{Min. Brightness}}{\text{Max. Brightness}} \times 100\%$$

, which is based on the brightness values of the 9 points measured by BM-5 as shown in Fig. 6.2.

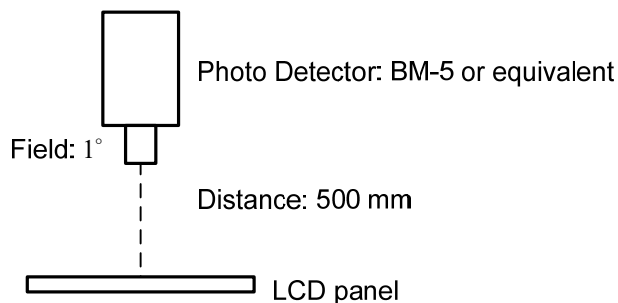

Fig. 6.1

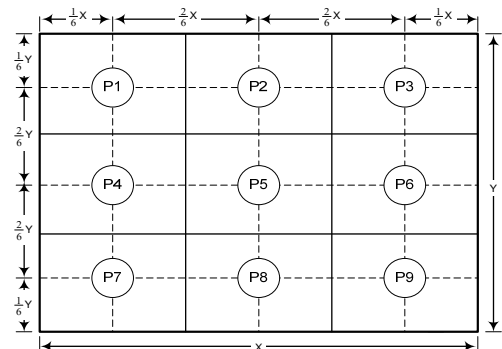

Fig. 6.2

Note 3: Continuously operating the test pattern (see below chess pattern Fig.6.3) on display for 2 hours at 25°C then switch to completely white pattern, the previous test pattern shall disappear within 2 seconds.

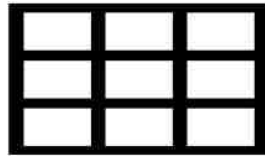

Fig.6.3

Note 4: The Contrast Ratio is measured from the center point of the panel, P5, and defined as the following equation:

$$CR = \frac{\text{Brightness of White}}{\text{Brightness of Black}}$$

Note 5: The definition of response time is shown in Fig. 6.4. The rising time is the period from 10% brightness to 90% brightness when the data is from black to white. Oppositely, Falling time is the period from 90% brightness falling to 10% brightness.

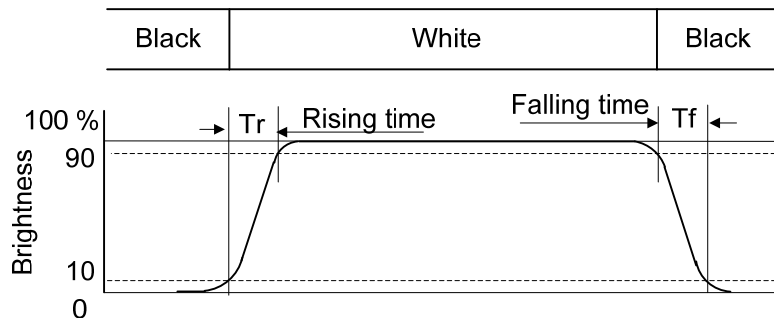

Fig.6.4

Note 6: The definition of viewing angle is shown in Fig. 6.5. Angle ϕ is used to represent viewing directions, for instance, $\phi = 270^\circ$ means 6 o'clock, and $\phi = 0^\circ$ means 3 o'clock. Moreover, angle θ is used to represent viewing angles from axis Z toward plane XY.

The display is super wide viewing angle version, so that the best optical performance can be obtained from every viewing direction.

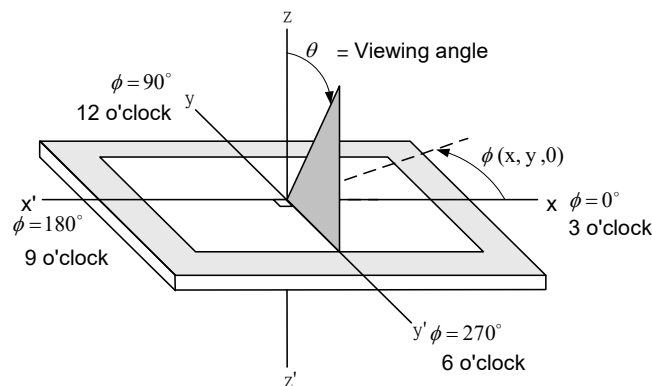
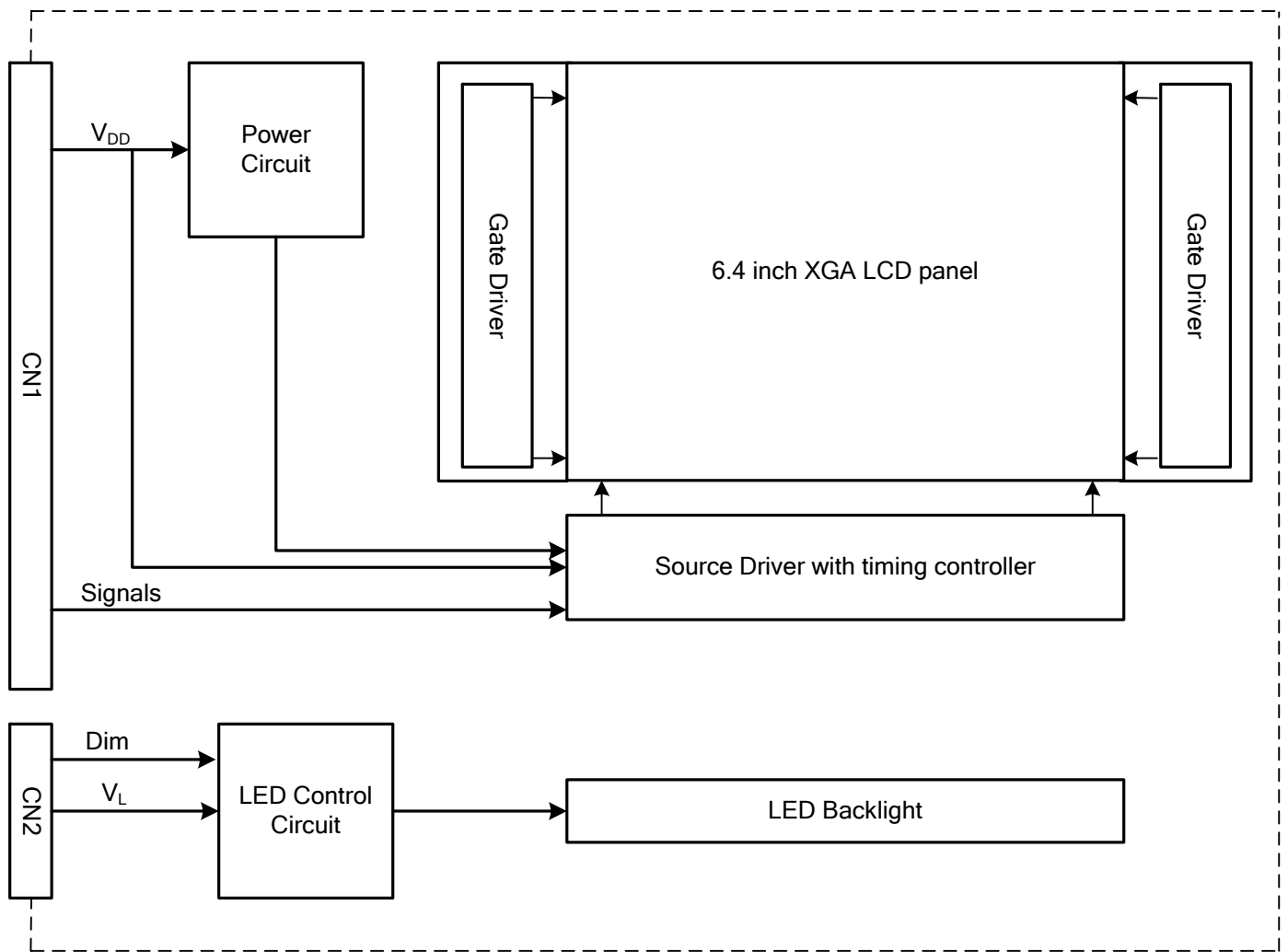

Fig 6.5

Note 7: The color chromaticity is measured from the center point of the panel, P5, as shown in Fig. 6.2.

7. BLOCK DIAGRAM



Note 1: Signals are SD, AMODE, CLK and pixel data pairs.

8. RELIABILITY TESTS

Test Item	Condition	
High Temperature	1) Operating 2) 80 °C	240 hrs
Low Temperature	1) Operating 2) -30 °C	240 hrs
High Temperature	1) Storage 2) 80 °C	240 hrs
Low Temperature	1) Storage 2) -30 °C	240 hrs
Heat Cycle	1) Operating 2) -20 °C ~70 °C 3) 3hrs~1hr~3hrs	240 hrs
Thermal Shock	1) Non-Operating 2) -35 °C ↔ 85 °C 3) 0.5 hr ↔ 0.5 hr	240 hrs
High Temperature & Humidity	1) Operating 2) 40 °C & 85%RH 3) Without condensation	240 hrs (Note 3)
Vibration	1) Non-Operating 2) 20~200 Hz 3) 2G 4) X, Y, and Z directions	1 hr for each direction
Mechanical Shock	1) Non-Operating 2) 10 ms 3) 50G 4) ±X, ±Y and ±Z directions	Once for each direction
ESD	1) Operating 2) Tip: 150 pF, 330 Ω 3) Air discharge for glass: ± 8KV 4) Contact discharge for metal frame: ± 8KV	1) Glass: 9 points 2) Metal frame: 8 points (Note 4)

Note 1: Display functionalities are inspected under the conditions defined in the specification after the reliability tests.

Note 2: The display is not guaranteed for use in corrosive gas environments.

Note 3: Under the condition of high temperature & humidity, if the temperature is higher than 40 °C, the humidity needs to be reduced as Fig. 8.1 shown.

Note 4: All pins of LCD interface (CN1) have been tested by ± 100V contact discharge of ESD under non-operating condition.

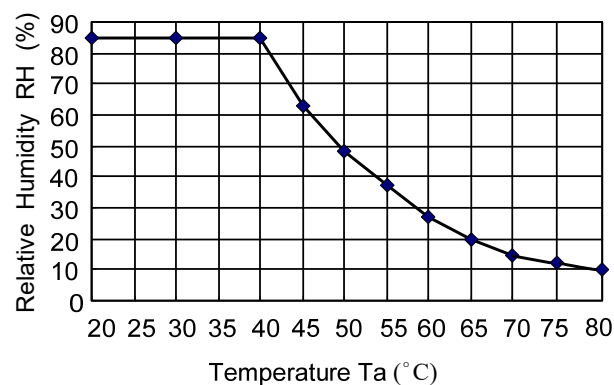

Fig. 8.1

9. LCD INTERFACE

9.1 INTERFACE PIN CONNECTIONS

The display interface connector (CN1) is DF14H-20P-1.25H made by HIROSE and pin assignment is as below:

Pin No.	Symbol	Signal	Pin No.	Symbol	Signal
1	V _{DD}	Power Supply for Logic	11	IN2-	Pixel Data
2	V _{DD}		12	IN2+	
3	V _{SS}	GND	13	V _{SS}	GND
4	V _{SS}		14	CLK IN-	Pixel Clock
5	IN0-	Pixel Data	15	CLK IN+	
6	IN0+		16	V _{SS}	GND
7	V _{SS}	GND	17	IN3-	Pixel Data
8	IN1-	Pixel Data	18	IN3+	
9	IN1+		19	SD	Scan Direction Control (Note 2)
10	V _{SS}	GND	20	AMODE	Open / L:JEIDA, H:VESA

Note 1: IN n- and IN n+ (n=0, 1, 2, 3), CLK IN- and CLK IN+ should be wired by twist-pairs or side-by-side FPC patterns, respectively.

Note 2: Scan direction is available to be switched as below.



SD : H



SD : L or open

The backlight connector (CN2) is SM06B-SHLS-TF, and pin assignment is as below:

Pin No.	Signal	Signal
1	V _{LED}	12VDC
2	V _{LED}	12VDC
3	GND	Ground
4	GND	Ground
5	V _{LED}	12VDC
6	DIM	3.3V @200Hz~1000Hz

Note 3: The relationship of brightness and Dim control are shown as below.

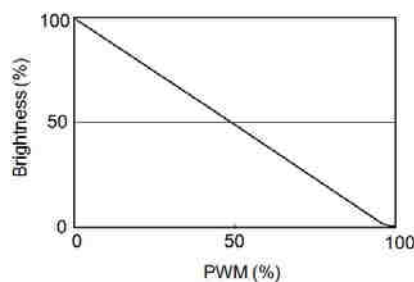

9.2 TIMING CHART

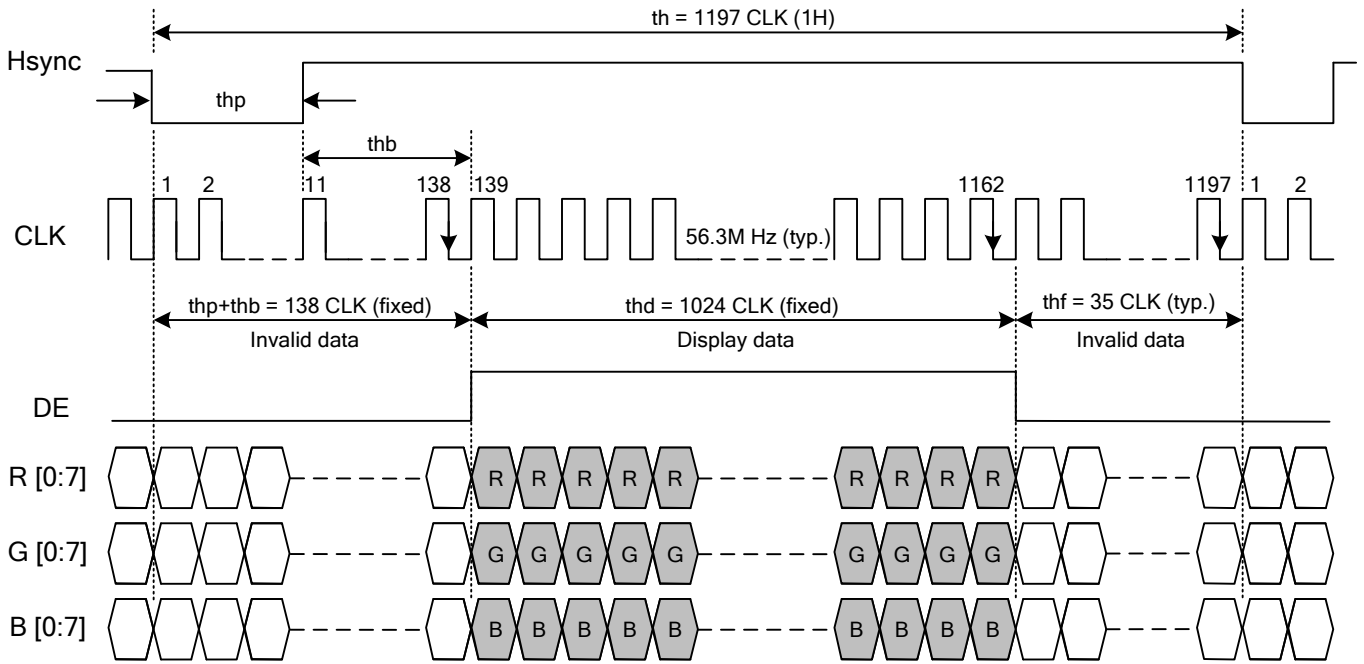

Fig. 9.1 Horizontal Timing of VS-HS-DE Mode

Note 1: CLK's falling edge is the time to latch data and count ($thp + thb$), therefore, data sending and Hsync's falling edge should start when CLK's rise edge.

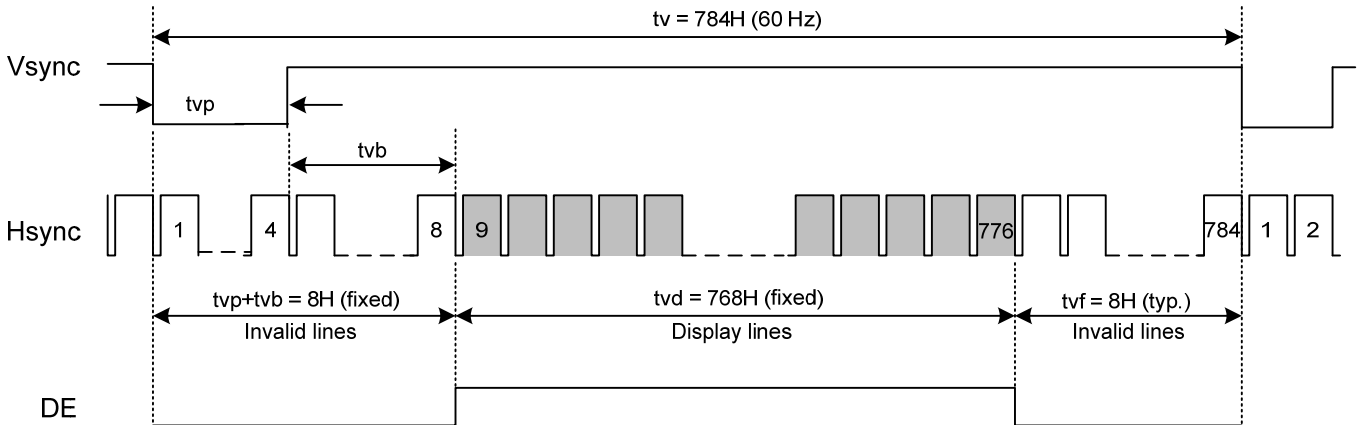
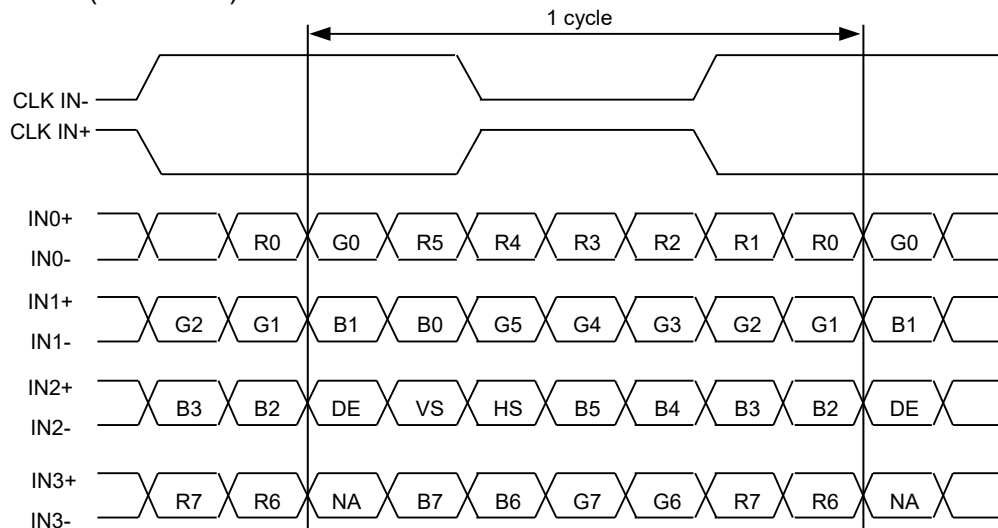

Fig. 9.2 Vertical Timing of VS-HS-DE Mode

Note 2: Vsync's falling edge needs to start with Hsync's falling edge simultaneously to count ($tv_p + tv_b$).

LVDS DATA FORMAT

(1) 8Bit Mode (Amode=H)



(2) 8Bit Mode (Amode=L/Open)

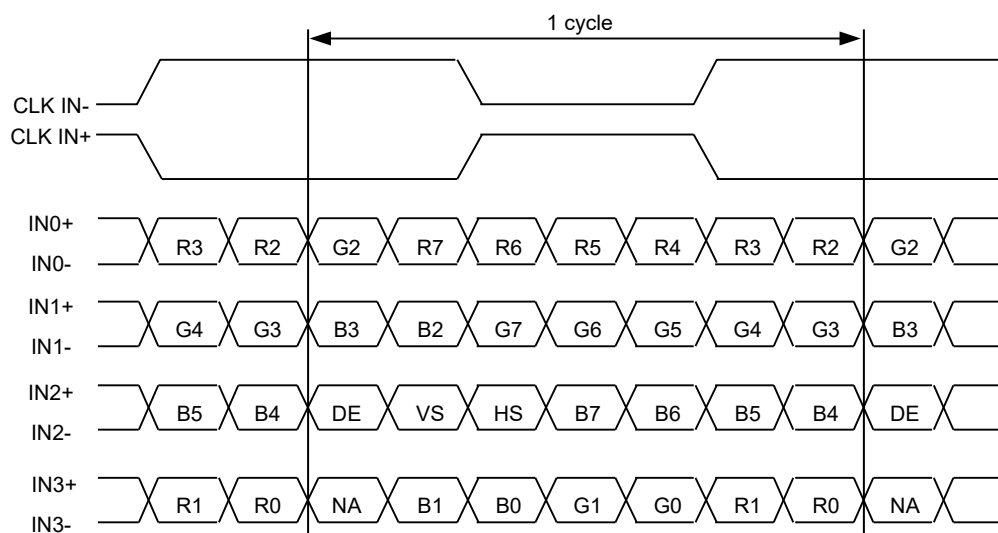

9.3 TIME TABLE

The column of timing sets including minimum, typical, and maximum as below are based on the best optical performance, frame frequency (f_{Frame}) = 60 Hz to define. If 60 Hz is not the aim to set, 55~65 Hz for f_{Frame} is recommended to apply for better performance by other parameter combination as the definitions in section 5.1.

A. HS-VS-DE MODE

	Item	Symbol	Min.	Typ.	Max.	Unit
Horizontal	CLK Frequency	fclk	51	56.3	66	M Hz
	Display Data	thd	1024	1024	1024	CLK
	Cycle Time	th	1096	1197	1295	
	Pulse Width	thp	2	10	20	
	Pulse Width and Back Porch	thp + thb	42	138	206	
	Front Porch	thf	30	35	65	
Vertical	Display Line	tvd	768	768	768	H
	Cycle Time	tv	776	784	849	
	Pulse Width	tvp	2	4	10	
	Pulse Width and Back Porch	tvp + tvb	6	8	35	
	Front Porch	tvf	2	8	20	

9.4 LVDS RECEIVER TIMING

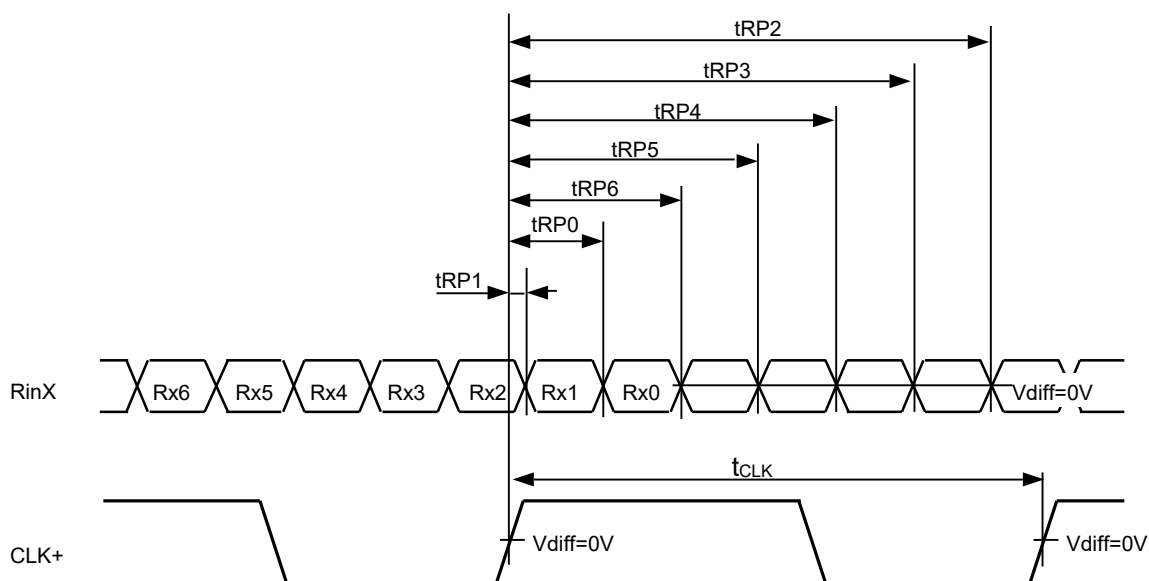

$$RinX = (RinX+) - (RinX-) \quad (X=0, 1, 2, 3)$$

	Item	Symbol	Min.	Typ.	Max.	Unit
CLK	Cycle frequency	$1/t_{CLK}$	51	56.3	66	MHz
RinX (X=0,1,2,3)	0 data position	t_{RP0}	$1/7 * t_{CLK} - 0.55$	$1/7 * t_{CLK}$	$1/7 * t_{CLK} + 0.55$	ns
	1st data position	t_{RP1}	-0.55	0	+0.55	
	2nd data position	t_{RP2}	$6/7 * t_{CLK} - 0.55$	$6/7 * t_{CLK}$	$6/7 * t_{CLK} + 0.55$	
	3rd data position	t_{RP3}	$5/7 * t_{CLK} - 0.55$	$5/7 * t_{CLK}$	$5/7 * t_{CLK} + 0.55$	
	4th data position	t_{RP4}	$4/7 * t_{CLK} - 0.55$	$4/7 * t_{CLK}$	$4/7 * t_{CLK} + 0.55$	
	5th data position	t_{RP5}	$3/7 * t_{CLK} - 0.55$	$3/7 * t_{CLK}$	$3/7 * t_{CLK} + 0.55$	
	6th data position	t_{RP6}	$2/7 * t_{CLK} - 0.55$	$2/7 * t_{CLK}$	$2/7 * t_{CLK} + 0.55$	

9.5 DATA INPUT for DISPLAY COLOR

Input		Red Data								Green Data								Blue Data															
		R7	R6	R5	R4	R3	R2	R1	R0	G7	G6	G5	G4	G3	G2	G1	G0	B7	B6	B5	B4	B3	B2	B1	B0								
color		MSB								LSB								MSB								LSB							
Basic Color	Black	0	0	0	0	0	0	0	0	0	0	0	0	0	0	0	0	0	0	0	0	0	0	0	0								
	Red(255)	1	1	1	1	1	1	1	1	0	0	0	0	0	0	0	0	0	0	0	0	0	0	0									
	Green(255)	0	0	0	0	0	0	0	0	1	1	1	1	1	1	1	0	0	0	0	0	0	0	0									
	Blue(255)	0	0	0	0	0	0	0	0	0	0	0	0	0	0	0	1	1	1	1	1	1	1	1									
	Cyan	0	0	0	0	0	0	0	0	1	1	1	1	1	1	1	1	1	1	1	1	1	1	1									
	Magenta	1	1	1	1	1	1	1	1	0	0	0	0	0	0	0	1	1	1	1	1	1	1	1									
	Yellow	1	1	1	1	1	1	1	1	1	1	1	1	1	1	1	0	0	0	0	0	0	0	0									
	White	1	1	1	1	1	1	1	1	1	1	1	1	1	1	1	1	1	1	1	1	1	1	1									
Red	Black	0	0	0	0	0	0	0	0	0	0	0	0	0	0	0	0	0	0	0	0	0	0										
	Red(1)	0	0	0	0	0	0	0	1	0	0	0	0	0	0	0	0	0	0	0	0	0	0										
	Red(2)	0	0	0	0	0	0	1	0	0	0	0	0	0	0	0	0	0	0	0	0	0	0										
	:	:	:	:	:	:	:	:	:	:	:	:	:	:	:	:	:	:	:	:	:	:	:										
	:	:	:	:	:	:	:	:	:	:	:	:	:	:	:	:	:	:	:	:	:	:	:										
	Red(253)	1	1	1	1	1	1	0	1	0	0	0	0	0	0	0	0	0	0	0	0	0	0										
	Red(254)	1	1	1	1	1	1	1	0	0	0	0	0	0	0	0	0	0	0	0	0	0	0										
	Red(255)	1	1	1	1	1	1	1	0	0	0	0	0	0	0	0	0	0	0	0	0	0	0										
Green	Black	0	0	0	0	0	0	0	0	0	0	0	0	0	0	0	0	0	0	0	0	0	0										
	Green(1)	0	0	0	0	0	0	0	0	0	0	0	0	0	1	0	0	0	0	0	0	0	0										
	Green(2)	0	0	0	0	0	0	0	0	0	0	0	0	1	0	0	0	0	0	0	0	0											
	:	:	:	:	:	:	:	:	:	:	:	:	:	:	:	:	:	:	:	:	:	:											
	:	:	:	:	:	:	:	:	:	:	:	:	:	:	:	:	:	:	:	:	:	:											
	Green(253)	0	0	0	0	0	0	0	1	1	1	1	1	1	0	1	0	0	0	0	0	0											
	Green(254)	0	0	0	0	0	0	0	1	1	1	1	1	1	0	0	0	0	0	0	0	0											
	Green(255)	0	0	0	0	0	0	0	1	1	1	1	1	1	1	0	0	0	0	0	0	0											
Blue	Black	0	0	0	0	0	0	0	0	0	0	0	0	0	0	0	0	0	0	0	0	0	0										
	Blue(1)	0	0	0	0	0	0	0	0	0	0	0	0	0	0	0	0	0	0	0	0	0	1										
	Blue(2)	0	0	0	0	0	0	0	0	0	0	0	0	0	0	0	0	0	0	0	0	1	0										
	:	:	:	:	:	:	:	:	:	:	:	:	:	:	:	:	:	:	:	:	:	:	:										
	:	:	:	:	:	:	:	:	:	:	:	:	:	:	:	:	:	:	:	:	:	:	:										
	Blue(253)	0	0	0	0	0	0	0	0	0	0	0	0	0	0	1	1	1	1	1	1	0	1										
	Blue(254)	0	0	0	0	0	0	0	0	0	0	0	0	0	0	1	1	1	1	1	1	1	0										
	Blue(255)	0	0	0	0	0	0	0	0	0	0	0	0	0	0	1	1	1	1	1	1	1	1										

9.6 POWER SEQUENCE

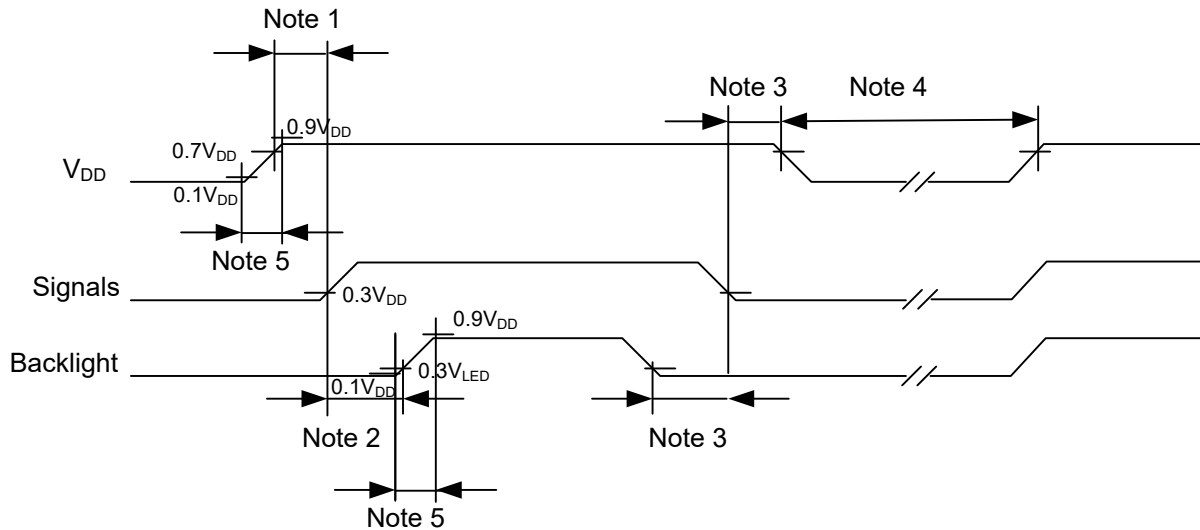

Note 1: In order to avoid any damages, V_{DD} has to be applied before all other signals. The recommended time period is 1 second (0.2 second is minimum). Hot plugging might cause display damage due to incorrect power sequence, please pay attention on interface connecting before power on.

Note 2: In order to avoid uncompleted patterns in transient state, It is recommended that switching the backlight on is delayed for 1 second after the signals have been applied (0.1 second is minimum).

Note 3: Off sequence is same. The time period from backlight off to signal off and signal off to power off are recommended 1 second. No damage is left if they are turned off simultaneously, but display irregular might be observed.

Note 4: In order to avoid any damages, the interval time from power off to power on shall be 1 second minimum.

Note 5: In order to avoid high Inrush current, V_{DD} & V_{LED} rising time need to set at
 $0.5\text{ms} < V_{DD} \& V_{LED} < 10\text{ms}$.

10. OUTLINE DIMENSIONS

10.1 FRONT VIEW

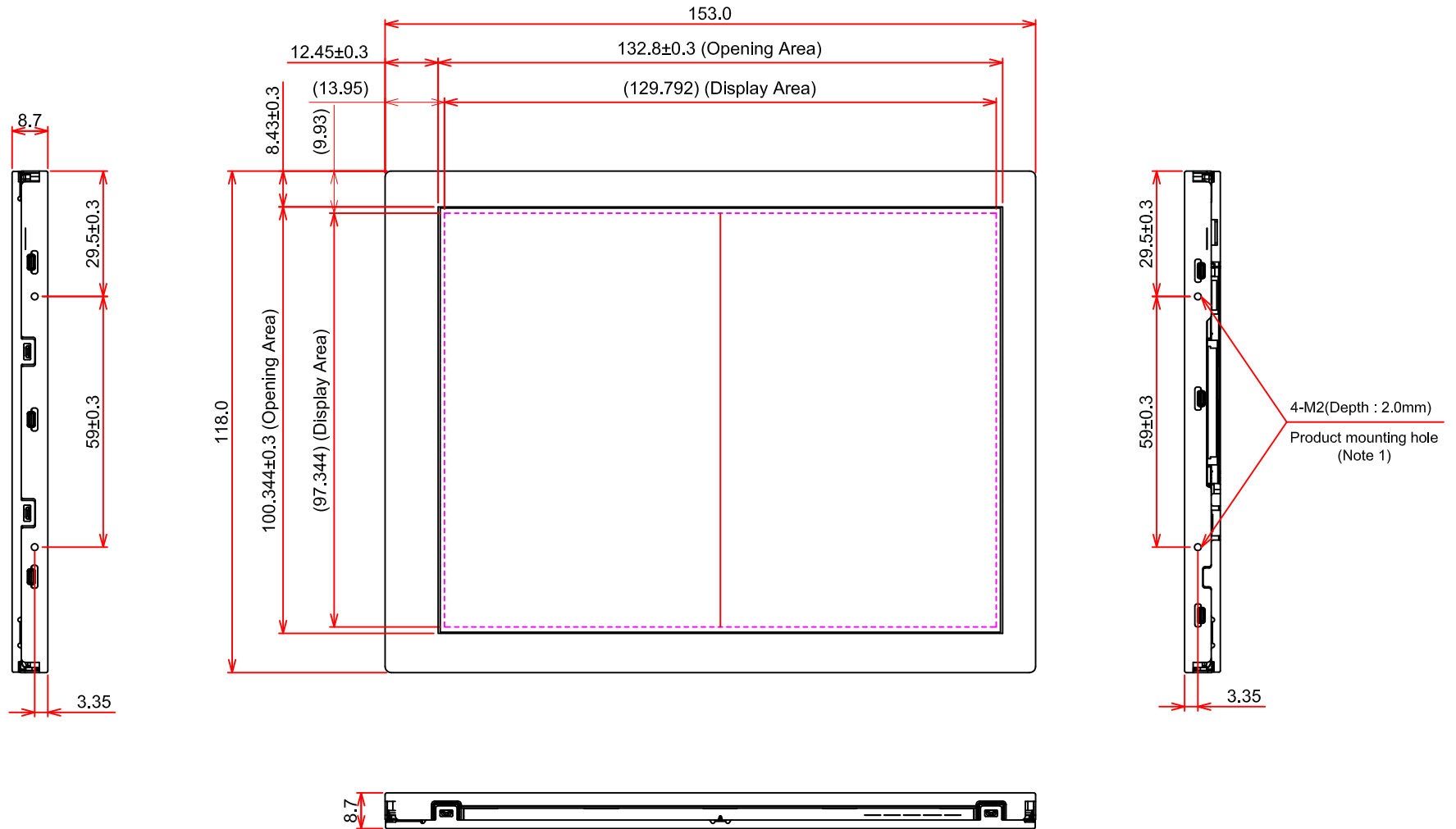

Note 1: Within 0.147Nm (1.5kgfcm) of M2 screw torque is recommended.

General Tolerance: ±0.5mm
Scale : NTS
Unit : mm

10.2 REAR VIEW

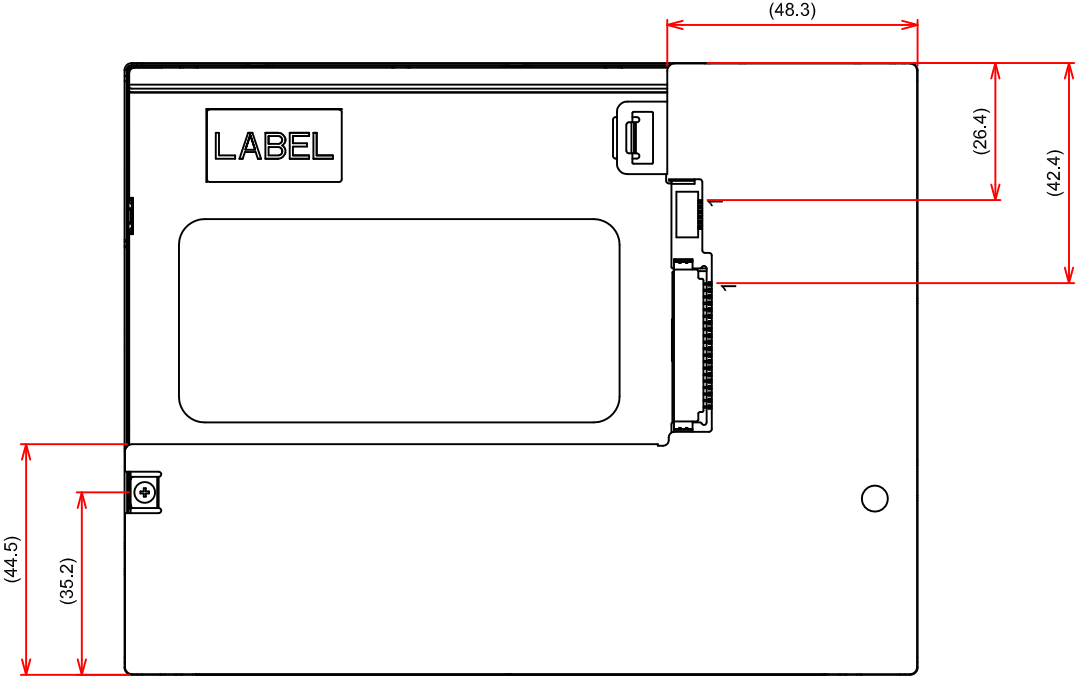

General Tolerance:±0.5mm
Scale : NTS
Unit : mm

11. APPEARANCE STANDARD

The appearance inspection is performed in a dark room around 500~1000 lx based on the conditions as below:

- The distance between inspector's eyes and display is 30 cm.
- The viewing zone is defined with angle θ shown in Fig. 11.1 The inspection should be performed within 45° when display is shut down. The inspection should be performed within 5° when display is power on.

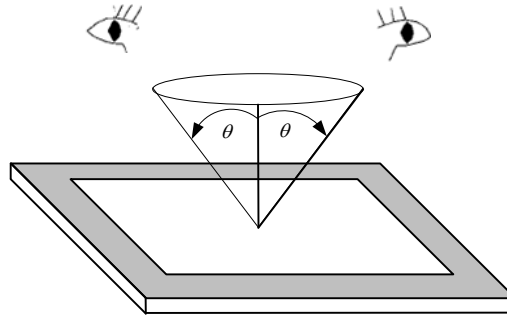

Fig. 11.1

11.1 THE DEFINITION OF LCD ZONE

LCD panel is divided into 3 areas as shown in Fig.11.2 for appearance specification in next section. A zone is the LCD active area (dot area); B zone is the area, which extended 1 mm out from LCD active area; C zone is the area between B zone and metal frame.

In terms of housing design, B zone is the recommended window area customers' housing should be located in.

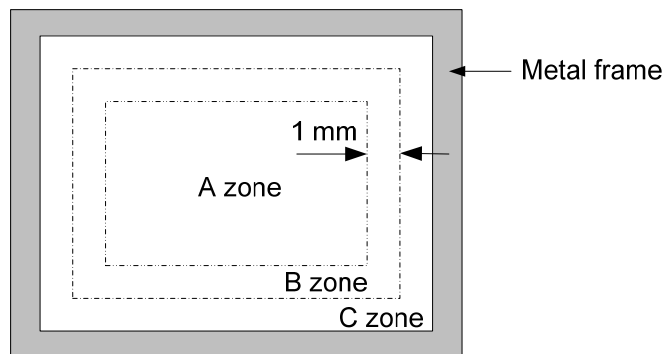

Fig. 11.2

11.2 LCD APPEARANCE SPECIFICATION

The specification as below is defined as the amount of unexpected phenomenon or material in different zones of LCD panel. The definitions of length, width and average diameter using in the table are shown in Fig. 11.3 and Fig. 11.4.

Item	Criteria				Applied zone
	Length (mm)	Width (mm)	Maximum number	Minimum space	
Scratches	Ignored	$W \leq 0.02$	Ignored	-	A, B
	$L \leq 40$	$0.02 < W \leq 0.04$	10	-	
	$L \leq 20$	$W \leq 0.04$	10	-	
Dent	Serious one is not allowed				A
Wrinkles in polarizer	Serious one is not allowed				A
Bubbles on polarizer	Average diameter (mm)		Maximum number		A
	$D \leq 0.3$		Ignored		
	$0.3 < D \leq 0.5$		12		
	$0.5 < D$		3		
1) Stains 2) Foreign Materials 3) Dark Spot	Filamentous (Line shape)				A, B
	Length (mm)	Width (mm)	Maximum number		
	$L \leq 2.0$	$W \leq 0.03$	Ignored		
	$L \leq 3.0$	$0.03 < W \leq 0.05$	10		
	$L \leq 2.5$	$0.05 < W \leq 0.1$	1		
	Round (Dot shape)				A, B
	Average diameter (mm)	Maximum number	Minimum Space		
	$D < 0.1$	Ignored	-		
	$0.1 \leq D < 0.3$	3	10 mm		
	$0.3 \leq D$	None	-		
In total		Filamentous + Round=10			
Those wiped out easily on the LCD surface are acceptable					
Dot-Defect (Note 1)			Type	Maximum number	A
	Bright dot-defect		1 dot	4	
			2 adjacent dot	1	
			3 adjacent dot or above	Not allowed	
			In total	5	
	Dark dot-defect		1 dot	5	
			2 adjacent dot	2	
			3 adjacent dot or above	Not allowed	
In total			5		
In total		10			

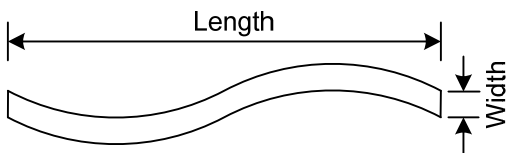
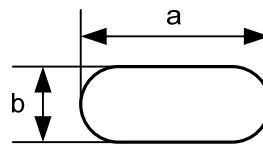

Fig. 11.3



$$\text{Average diameter} = \frac{a+b}{2}$$

Fig. 11.4

Note 1: The definitions of dot defect are as below:

- The defect area of the dot must be bigger than half of a dot.
- For bright dot-defect, showing black pattern, the dot's brightness must be over 30% brighter than others.
- For dark dot-defect, showing white pattern, the dot's brightness must be under 70% darker than others.
- The definition of 1-dot-defect is the defect-dot, which is isolated and no adjacent defect-dot.
- The definition of adjacent dot is shown as Fig. 11.5.

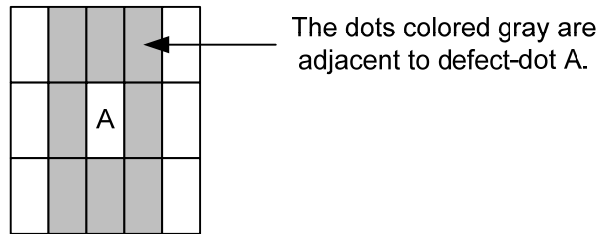

Fig. 11.5

12. PRECAUTIONS

12.1 PRECAUTIONS OF ESD

- 1) Before handling the display, please ensure your body has been connected to ground to avoid any damages by ESD. Also, do not touch display's interface directly when assembling.
- 2) Please remove the protection film very slowly before turning on the display to avoid generating ESD.

12.2 PRECAUTIONS OF HANDLING

- 1) In order to keep the appearance of display in good condition, please do not rub any surfaces of the displays by using sharp tools harder than 3H, especially touch panel, metal frame and polarizer.
- 2) Please do not stack the displays as this may damage the surface. In order to avoid any injuries, please avoid touching the edge of the glass or metal frame and wore gloves during handling.
- 3) Touching the polarizer or terminal pins with bare hand should be avoided to prevent staining and poor electrical contact.
- 4) Do not use any harmful chemicals such as acetone, toluene, and isopropyl alcohol to clean display's surfaces.
- 5) Please use soft cloth or absorbent cotton with ethanol to clean the display by gently wiping. Moreover, when wiping the display, please wipe it by horizontal or vertical direction instead of circling to prevent leaving scars on the display's surface, especially polarizer.
- 6) Please wipe any unknown liquids immediately such as saliva, water or dew on the display to avoid color fading or any permanent damages.
- 7) Maximum pressure to the surface of the display must be less than $1,96 \times 10^4$ Pa. If the area of applied pressure is less than 1 cm^2 , the maximum pressure must be less than 1.96N.

12.3 PRECAUTIONS OF OPERATING

- 1) Please input signals and voltages to the displays according to the values defined in the section of electrical characteristics to obtain the best performance. Any voltages over than absolute maximum rating will cause permanent damages to this display. Also, any timing of the signals out of this specification would cause unexpected performance.
- 2) When the display is operating at significant low temperature, the response time will be slower than it at 25 C° . In high temperature, the color will be slightly dark and blue compared to original pattern. However, these are temperature-related phenomenon of LCD and it will not cause permanent damages to the display when used within the operating temperature.
- 3) The use of screen saver or sleep mode is recommended when static images are likely for long periods of time. This is to avoid the possibility of image sticking.
- 4) Spike noise can cause malfunction of the circuit. The recommended limitation of spike noise is no bigger than $\pm 100 \text{ mV}$.

12.4 PRECAUTIONS OF STORAGE

If the displays are going to be stored for years, please be aware the following notices.

- 1) Please store the displays in a dark room to avoid any damages from sunlight and other sources of UV light.
- 2) The recommended long term storage temperature is between 10 C° ~35 C° and 55%~75% humidity to avoid causing bubbles between polarizer and LCD glasses, and polarizer peeling from LCD glasses.
- 3) It would be better to keep the displays in the container, which is shipped from KOE, and do not unpack it.
- 4) Please do not stick any labels on the display surface for a long time, especially on the polarizer.

13. DESIGNATION OF LOT MARK

1) The lot mark is showing in Fig.13.1. First 4 digits are used to represent production lot, T represented made in Taiwan, and the last 6 digits are the serial number.

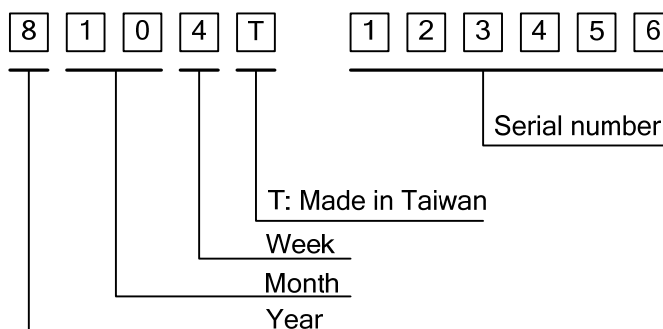

Fig. 13.1

2) The tables as below are showing what the first 4 digits of lot mark are shorted for.

Year	Lot Mark
2018	8
2019	9
2020	0
2021	1
2022	2

Month	Lot Mark	Month	Lot Mark
Jan.	01	Jul.	07
Feb.	02	Aug.	08
Mar.	03	Sep.	09
Apr.	04	Oct.	10
May	05	Nov.	11
Jun.	06	Dec.	12

Week	Lot Mark
1~7 days	1
8~14 days	2
15~21 days	3
22~28 days	4
29~31 days	5

3) Except letters I and O, revision number will be shown on lot mark and following letters A to Z.

REV. No	Item	Remarks
A	-	-

4) The location of the lot mark is on the back of the display shown in Fig. 13.2.

Label example:

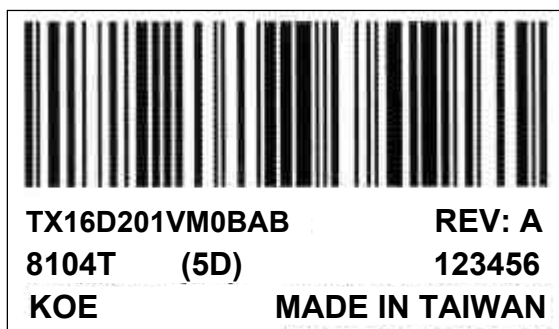

Fig. 13.2

Our company network supports you worldwide with offices in Germany, Austria, Switzerland, the UK and the USA. For more information please contact:

Headquarters

Germany



FORTEC Elektronik AG

Augsburger Str. 2b
82110 Germering

Phone: +49 89 894450-0
E-Mail: info@fortecaq.de
Internet: www.fortecaq.de

Fortec Group Members

Austria



Distec GmbH Office Vienna

Nuschinggasse 12
1230 Wien

Phone: +43 1 8673492-0
E-Mail: info@distec.de
Internet: www.distec.de

Germany



Distec GmbH

Augsburger Str. 2b
82110 Germering

Phone: +49 89 894363-0
E-Mail: info@distec.de
Internet: www.distec.de

Switzerland



ALTRAC AG

Bahnhofstraße 3
5436 Würenlos

Phone: +41 44 7446111
E-Mail: info@altrac.ch
Internet: www.altrac.ch

United Kingdom



Display Technology Ltd.

Osprey House, 1 Osprey Court
Hichingbrooke Business Park
Huntingdon, Cambridgeshire, PE29 6FN

Phone: +44 1480 411600
E-Mail: info@displaytechnology.co.uk
Internet: www.displaytechnology.co.uk

USA



Apollo Display Technologies, Corp.

87 Raynor Avenue,
Unit 1 Ronkonkoma,
NY 11779

Phone: +1 631 5804360
E-Mail: info@apolloDisplays.com
Internet: www.apolloDisplays.com