



OUR GLOBAL  
COMPETENCE  
CENTRES

 APOLLO DISPLAY  
TECHNOLOGIES



 DISTEC



 DISPLAY  
TECHNOLOGY



# Datasheet

## Kontron

### COMe-cWL6

COM Express Compact Type 6 Module with

Intel® 8th Generation Core i / Celeron 4000 U-Series Processors



---

The information contained in this document has been carefully researched and is, to the best of our knowledge, accurate. However, we assume no liability for any product failures or damages, immediate or consequential, resulting from the use of the information provided herein. Our products are not intended for use in systems in which failures of product could result in personal injury. All trademarks mentioned herein are property of their respective owners. All specifications are subject to change without notice.

---

# COMe-cWL6 (E2S)

---

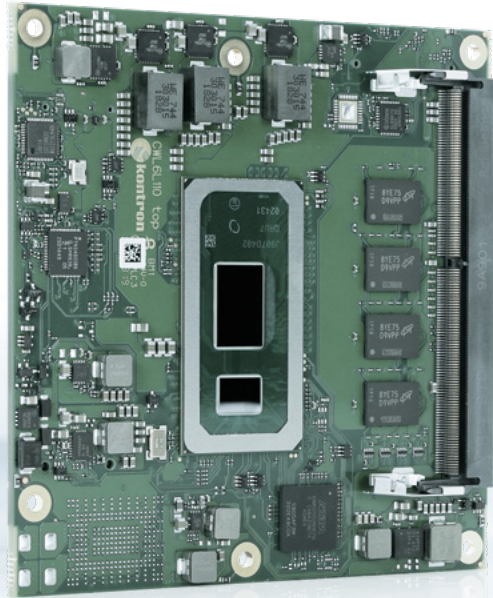

## COM Express® Compact Type 6 with 8th Generation Intel® Core™ / Celeron® Processors

- ▶ Up to 48 GByte DDR4 memory (16 GByte DDR4 memory down)
- ▶ Optional NVMe SSD onboard
- ▶ Industrial grade versions
- ▶ Kontron APPROTECT security solution based on Wibu-Systems CodeMeter®

POSSIBILITIES START HERE

## TECHNICAL INFORMATION

COMPLIANCE	COM Express® Compact Pin-out Type 6
DIMENSIONS (H X W)	95 x 95 mm
CPU	Intel® Core™ i7-8665UE, 4x 1.7 GHz, GT2, 15 W Intel® Core™ i5-8365UE, 4x 1.6 GHz, GT2, 15 W Intel® Core™ i3-8145UE, 2x 2.2 GHz, GT2, 15 W Intel® Celeron® 4305UE, 2x 2.0 GHz, GT1, 15 W
CHIPSET	Integrated SoC
MAIN MEMORY	1x DDR4 SO-DIMM up to 32 GByte, 2nd channel DDR4 memory down up to 16 GByte
GRAPHICS CONTROLLER	Intel® UHD Graphics 620 (Celeron® 4305UE: Intel® UHD Graphics 610)
ETHERNET CONTROLLER	Intel® I219LM
ETHERNET	10/100/1000 MBit Ethernet
HARD DISK	2x SATA 6Gb/s
FLASH ONBOARD	Up to 1 TByte NVMe SSD (on request)
PCI EXPRESS® SUPPORT	5x PCIe 3.0 (On request: 6x without Ethernet, up to 8x without Ethernet & SATA) 4x PCIe 3.0 on PEG Lanes #0-3
PANEL SIGNAL	DDI1: DP++, DDI2: DP++, DDI3: -, VGA: -, LVDS: Dual Channel 18/24 bit
USB	4x USB 3.1 (incl. USB 2.0) + 4x USB 2.0
SERIAL	2x serial interface (RX/TX only)
AUDIO	High Definition Audio interface
COMMON FEATURES	SPI, LPC, SMB, Fast I <sup>2</sup> C, Staged Watchdog, RTC, support of Intel® Optane™ memory technology via PCIe
BIOS	AMI Aptio V
HUMIDITY	93 % relative Humidity at 40 °C, non-condensing (according to IEC 60068-2-78)
FEATURES ON REQUEST	vPRO (AMT/TXT/AES Support), eDP instead of LVDS, VGA, up to 3x PCIe x1 additional w/o onboard LAN & SATA, NVMe SSD, Security Chip
POWER MANAGEMENT	ACPI 6.0
POWER SUPPLY	8.5 V – 20 V Wide Range, Single Supply Power
SPECIAL FEATURES	POSCAP capacitors, Trusted Platform Module TPM 2.0
OPERATING SYSTEM	Windows®10, Linux, VxWorks
TEMPERATURE	Commercial temperature: 0 °C to +60 °C operating, -30 °C to +85 °C non-operating Extended temperature: -25 °C to +75 °C operating, -30 °C to +85 °C non-operating Industrial temperature: -40 °C to +85 °C operating, -40 °C to +85 °C non-operating
SUPPORTED MODULES	COMe-cWL6 (E25) xx-xxxxxx

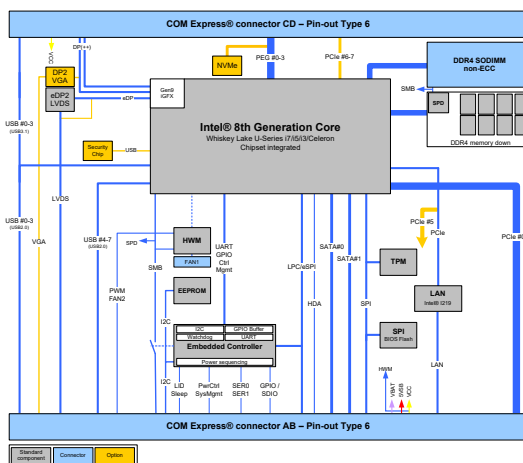

## Global Headquarters

### Kontron S&T AG

Lise-Meitner-Str. 3-5  
86156 Augsburg, Germany  
Tel.: + 49 821 4086 0  
Fax: + 49 821 4086 111  
info@kontron.com  
[www.kontron.com](http://www.kontron.com)

Our company network supports you worldwide with offices in Germany, Austria, Switzerland, the UK and the USA. For more information please contact:

## Headquarters

### Germany



#### FORTEC Elektronik AG

Augsburger Str. 2b  
82110 Germering

Phone: +49 89 894450-0  
E-Mail: [info@forteca.de](mailto:info@forteca.de)  
Internet: [www.forteca.de](http://www.forteca.de)

## Fortec Group Members

### Austria



#### Distec GmbH Office Vienna

Nuschinggasse 12  
1230 Wien

Phone: +43 1 8673492-0  
E-Mail: [info@distec.de](mailto:info@distec.de)  
Internet: [www.distec.de](http://www.distec.de)

### Germany



#### Distec GmbH

Augsburger Str. 2b  
82110 Germering

Phone: +49 89 894363-0  
E-Mail: [info@distec.de](mailto:info@distec.de)  
Internet: [www.distec.de](http://www.distec.de)

### Switzerland



#### ALTRAC AG

Bahnhofstraße 3  
5436 Würenlos

Phone: +41 44 7446111  
E-Mail: [info@altrac.ch](mailto:info@altrac.ch)  
Internet: [www.altrac.ch](http://www.altrac.ch)

### United Kingdom



#### Display Technology Ltd.

Osprey House, 1 Osprey Court  
Hichingbrooke Business Park  
Huntingdon, Cambridgeshire, PE29 6FN

Phone: +44 1480 411600  
E-Mail: [info@displaytechnology.co.uk](mailto:info@displaytechnology.co.uk)  
Internet: [www.displaytechnology.co.uk](http://www.displaytechnology.co.uk)

### USA



#### Apollo Display Technologies, Corp.

87 Raynor Avenue,  
Unit 1 Ronkonkoma,  
NY 11779

Phone: +1 631 5804360  
E-Mail: [info@apolloDisplays.com](mailto:info@apolloDisplays.com)  
Internet: [www.apolloDisplays.com](http://www.apolloDisplays.com)